

AB1 A4



CE1 STAINLESS STEEL HEAVY-DUTY EXPANSION ANCHOR

- CE option 1 for cracked and uncracked concrete
- Seismic performance category C1
- A4 stainless steel
- Fire resistance R120
- Complete with nut and washer
- Suitable for dense materials
- Through fastening
- Torque-controlled expansion



CODES AND DIMENSIONS

CODE	$d = d_0$ [mm]	L_t [mm]	t_{fix} [mm]	$h_{1,min}$ [mm]	h_{nom} [mm]	h_{ef} [mm]	d_f [mm]	SW [mm]	T_{inst} [Nm]	pcs
AB1892A4	M8	92	30	60	50	45	9	13	20	50
AB18112A4		112	50	60	50	45	9	13	20	50
AB11092A4	M10	92	10	75	68	60	12	17	35	50
AB110132A4		132	50	75	68	60	12	17	35	25
AB112118A4	M12	118	20	90	81	70	14	19	70	20
AB116138A4	M16	138	20	110	96	85	18	24	120	10

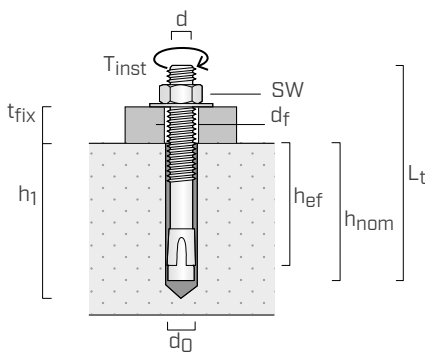

- d** anchor diameter
- d₀** hole diameter in the concrete support
- L_t** anchor length
- t_{fix}** maximum fastening thickness
- h₁** minimum hole depth
- h_{nom}** nominal anchoring depth
- h_{ef}** effective anchor depth
- d_f** maximum hole diameter in the element to be fastened
- SW** wrench size
- T_{inst}** tightening torque

ASSEMBLY

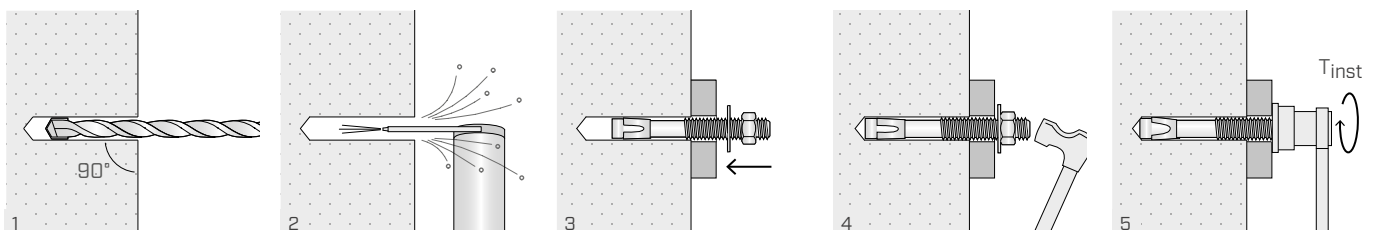

INSTALLATION

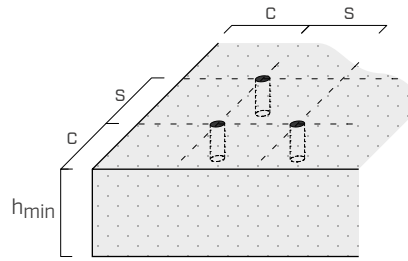

Spacing and minimum distances		AB1 A4			
		M8	M10	M12	M16
Minimum spacing	s_{min} [mm]	50	55	60	70
	for $c \geq$ [mm]	50	80	90	120
Minimum edge distance	c_{min} [mm]	50	50	55	85
	for $s \geq$ [mm]	50	100	145	150
Minimum thickness of concrete support	h_{min} [mm]	100	120	140	170
Spacing and critical distances		M8	M10	M12	M16
Critical spacing	$s_{cr,N}^{(1)}$ [mm]	135	180	210	255
	$s_{cr,sp}^{(2)}$ [mm]	180	240	280	340
Critical edge distance	$c_{cr,N}^{(1)}$ [mm]	68	90	105	128
	$c_{cr,sp}^{(2)}$ [mm]	90	120	140	170

For spacing and distances smaller than the critical ones, strength values have to be reduced depending on the installation parameters.

STATIC VALUES

Valid for a single anchor in thickened C20/25 grade concrete with a thin reinforcing layer when spacing and edge-distance are not limiting parameters.

CHARACTERISTIC VALUES

rod	UNCRACKED CONCRETE				CRACKED CONCRETE			
	tension ⁽³⁾		shear ⁽⁴⁾		tension ⁽³⁾		shear	
	$N_{Rk,p}$ [kN]	γ_{Mp}	$V_{Rk,s}$ [kN]	γ_{Ms}	$N_{Rk,p}$ [kN]	γ_{Mp}	$V_{Rk,s}$ [kN]	γ_M
M8	9	1,8	11	1,25	5	1,8	11	$\gamma_{Mc} = 1,5^{(5)}$
M10	16	1,8	17	1,25	9	1,8	17	$\gamma_{Ms} = 1,25^{(4)}$
M12	20	1,8	25	1,25	12	1,8	25	$\gamma_{Ms} = 1,25^{(4)}$
M16	35	1,5	47	1,25	20	1,5	47	$\gamma_{Ms} = 1,25^{(4)}$

incremental factor for $N_{Rk,p}^{(6)}$

ψ_c		
	C25/30	1,04
	C30/37	1,10
	C40/50	1,20
	C50/60	1,28

NOTES:

- (1) Breakage characteristics for formation of concrete cone for tensile loads.
- (2) Splitting failure mode for tensile loads.
- (3) Pull-out failure mode.
- (4) Steel failure mode.
- (5) Pry-out failure mode.
- (6) Tensile-strength increment factor (excluding steel failure).

GENERAL PRINCIPLES:

- Characteristic values according to ETA-10/0076.
- The design values are obtained from the characteristic values as follows:
 $R_d = R_k / \gamma_M$
Coefficients γ_M are listed in the table in accordance with the failure characteristics and product certificates.
- For the calculation of anchors with reduced spacing, or too close to the edge, please refer to ETA. Similarly, in case of fastening on concrete-supports with a better-grade, limited thickness or a thick reinforcing layer please see ETA.
- When designing anchors under seismic load please refer to the ETA referral document and information in the EOTA Technical Report 045.
- For the calculation of anchors subjected to fire refer to the ETA and the Technical Report 020.