

CLT AND MASS TIMBER

Solutions to design and build with solid wood panel systems



 **rothoblaas**

Solutions for Building Technology

LOAD-BEARING WALL CONSTRUCTION SYSTEM

HORIZONTAL LOADS

During the design phase of a building its reaction to horizontal and vertical actions such as, **wind** and/or **earthquakes** must be considered.

Horizontal actions can be schematised as loads acting on the floor levels. To guarantee the adequate seismic performance of timber buildings and avoid all the possible failure modes, it is fundamental to design all the connection systems correctly.

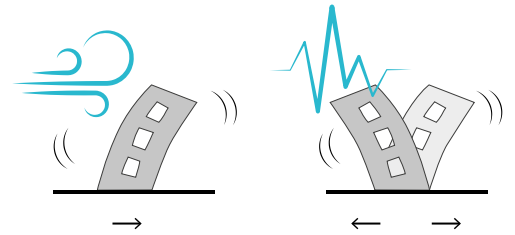

LOAD PATTERN

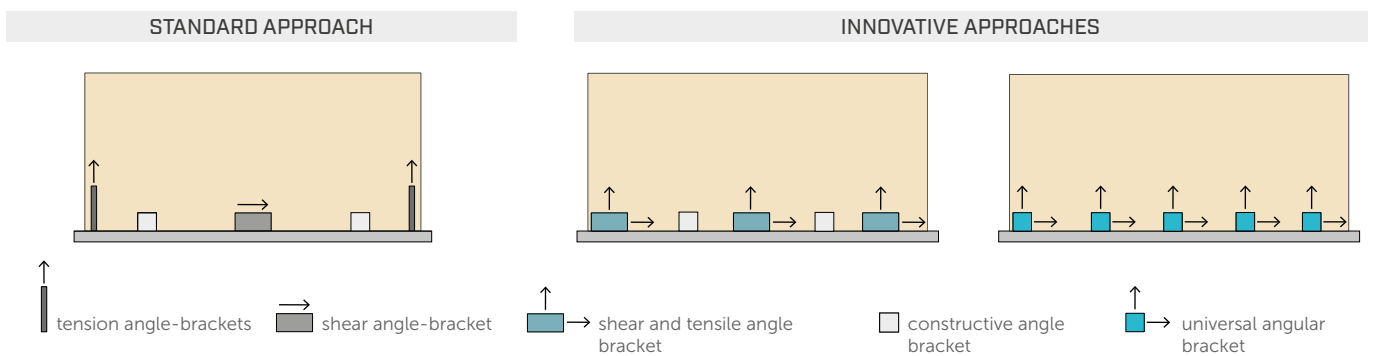

Horizontal loads acting at the floor level introduce shear and tension forces on the structural elements of the building; these forces must be absorbed by an effective connection system. A complete range of joints for walls and buildings also allows for innovative design approaches.

THE RIGHT SOLUTION FOR EVERY JOINT

The same structural problem can be solved using different alternative connection systems.

	TWO-DIMENSIONAL PLATES	THREE-DIMENSIONAL ANGLE BRACKETS	CONCEALED JOINTS	DISTRIBUTED JOINTS
INTERMEDIATE FLOOR JOINT				
	WHT/TITAN PLATE T TIMBER	NINO/TITAN/WKR/WHT	RADIAL	VGZ/HBS
BASE JOINT				
	WHT/TITAN PLATE C CONCRETE	NINO/TITAN/WKR/WHT	RING	ALU START

CLT AND MASS TIMBER CONNECTIONS

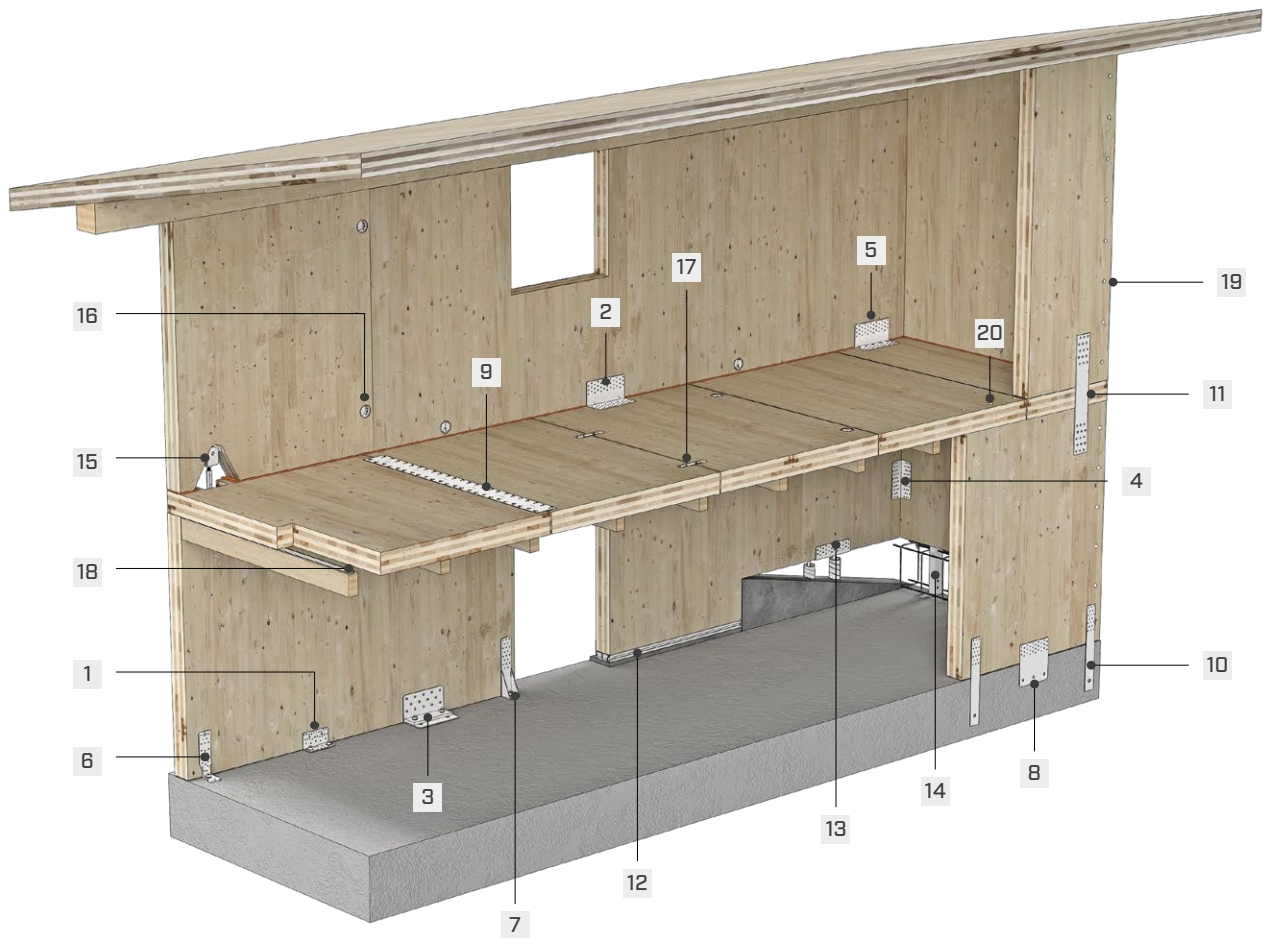

ANGLE BRACKETS

They are used for both timber-to-timber and timber-to-concrete connections. Depending on the specific model, they can be used to transfer tensile and shear forces, or a combination of both forces. The addition of special washers improves their performance and versatility.

- 1 NIND
- 2 TITAN N
- 3 TITAN S + WASHER
- 4 TITAN F
- 5 TITAN V
- 6 WKR
- 7 WHT

TWO-DIMENSIONAL PLATES

They allow the transfer of both tensile and shear forces; depending on the type used, they are suitable for both timber-to-timber and timber-to-concrete connections. Using fasteners with different diameters means that a wide range of strengths can be covered.

- 8 TITAN PLATE C
- 9 TITAN PLATE T
- 10 WHT PLATE C
- 11 WHT PLATE T

SPECIAL CONNECTORS

A new range of simple solutions are available to solve complex problems from small residential buildings to multi-storey buildings. These solutions offer the opportunity for designers and builders to break the mould and find innovative solutions.

- 12 ALU START
- 13 TITAN DIVE
- 14 UP LIFT
- 15 RADIAL
- 16 RING
- 17 SLOT
- 18 SHARP METAL

SELF-DRILLING SCREWS

The self-drilling product range of screws that provide an optimal solution to satisfy the design requirements regardless of the type of external action.

- 19 HBS/TBS
- 20 VGZ

CONNECTION TO THE GROUND TOLERANCE MANAGEMENT



UPLIFT

SYSTEM FOR BUILDINGS RAISED INSTALLATION

It allows the construction of timber walls resting on a reinforced concrete kerb. The raised installation allows the wall to be moved away from the ground for optimal durability.

The supports carry the weight of the building up to the completion of the reinforced concrete kerb and resist tensile and shear forces caused by earthquake or wind.



S355
Fe/Zn20a



ALU START

ALUMINIUM SYSTEM FOR THE CONNECTION OF BUILDINGS TO THE GROUND

The profile allows to eliminates contact between the timber panels and the concrete substructure. Excellent durability of the building connection to the ground.



alu
6060

DESIGN
REGISTERED

CE
ETA-20/0835

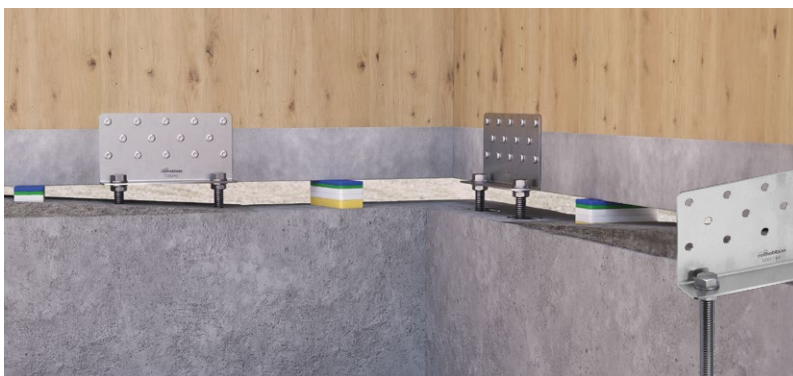

TITAN DIVE

ADVANCED HIGH-TOLERANCE ANGLE BRACKET

It allows maximum freedom in the installation of timber walls by avoiding the need to drill holes in the concrete substrate, which saves considerable time on site.



S235
Fe/Zn12c

DX51D
Z275

PATENTED

Discover the complete range of **PLATES AND CONNECTORS FOR TIMBER** on our website or ask your trusted agent for the catalogue.
www.rothoblaas.com

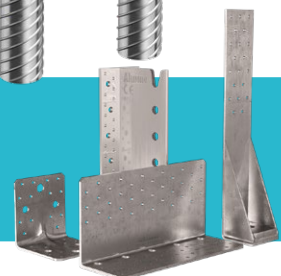

CONNECTION TO THE GROUND WATERPROOFING



START BAND

WATERPROOFING PROFILE WITH HIGH MECHANICAL RESISTANCE

It is compatible with bitumen, it does not degrade and it is UV-resistant. It is resistant to walking wear and cold temperatures.



GROUND BAND

SELF-ADHESIVE BITUMINOUS MEMBRANE

The special elastoplastomeric bituminous mix and the cross-laminated high-density polyethylene backing film make the product completely waterproof and resistant to punching shear. Effective installation from -5 °C to +30 °C. Remains flexible down to -30 °C.



PROTECT

SELF-ADHESIVE BUTYL BAND, CAN BE PLASTERED

The special mix guarantees excellent adhesion and deformation capacities, compensating for the natural movement of the timber. The butyl guarantees excellent adhesion to the supports also under difficult environmental conditions.

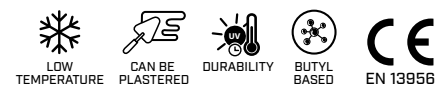

✓ RELATED PRODUCTS

BYTUM PRIMER

UNIVERSAL PRIMER FOR MEMBRANES AND BITUMINOUS TAPES



FLUID MEMBRANE

SYNTHETIC SEALING MEMBRANE FOR BRUSH AND SPRAY APPLICATION



PUMP SPRAY

ELECTRIC AIRLESS SPRAYER



WALLS FASTENING



WHT ANGLE BRACKET FOR TENSILE LOADS

Angle brackets suitable for CLT, LVL or timber frame walls. Ideal for timber-to-timber, timber-to-concrete and timber-to-steel configurations, and available in various sizes.

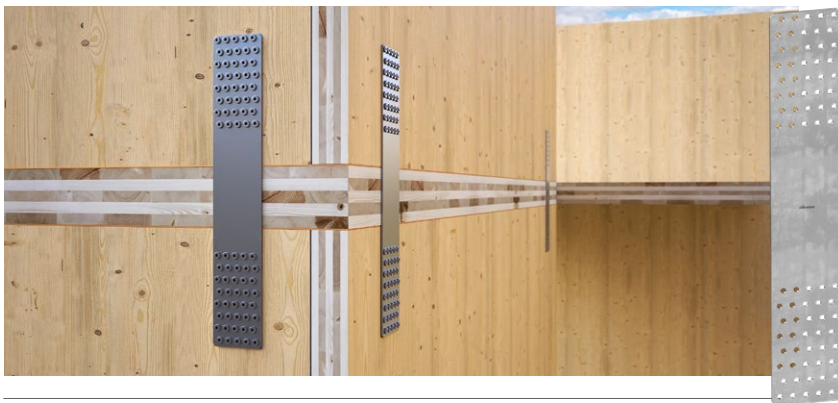

WHT PLATE T PLATE FOR TENSILE LOADS

Ideal for use on CLT for multi-storey buildings, they are all calculated and certified for tensile loads on timber-to-timber joints. Also available in the WHT PLATE C version for timber-to-concrete joints.



NINO UNIVERSAL ANGLE BRACKET FOR SHEAR AND TENSILE LOADS

ETA-certified universal angle brackets for multi-directional forces, suitable for fastening CLT or timber frame walls. Also suitable for non-structural applications and available in four sizes to meet different fastening requirements.



TITAN ANGLE BRACKETS FOR SHEAR AND TENSILE FORCES

High-performance angle brackets for timber-to-timber, timber-to-concrete and timber-to-steel joints in elements such as CLT, LVL, panels and timber frame structures. Available in versions designed for multidirectional loads, shear resistance or combined configurations.

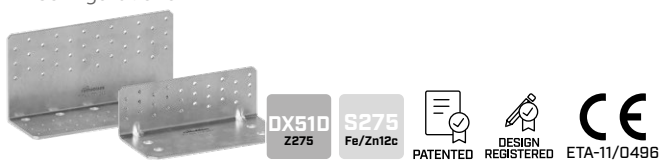

TITAN PLATE T PLATES FOR TIMBER

It is designed to withstand shear forces, is ideal for creating timber-to-timber joints, such as the flat connection of timber platform beams to load-bearing timber panels. Also available in the TITAN PLATE C version for timber-to-concrete joints.



RELATED PRODUCTS

WKR
TENSILE ANGLE BRACKET FOR BUILDINGS

LBA
HIGH BOND NAIL

LBS
ROUND HEAD SCREW FOR PLATES

PLUGS AND RESINS



SKR | SKS | SKP

SCREW-IN ANCHOR FOR CONCRETE

The special threading requires a small pre-drill and guarantees fastening on concrete without creating expansion stresses within it. Also available in the EVO C4 EVO version, suitable for atmospheric corrosivity class C4 and service class 3.

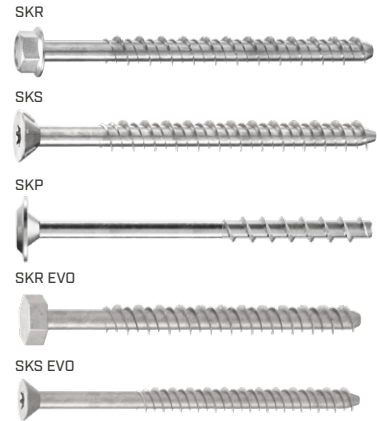

HYB-FIX

HIGH-PERFORMANCE HYBRID CHEMICAL ANCHOR

It is the high-performance hybrid chemical anchor ideal for extra-heavy anchor systems and for recasting with reinforcing bars. Effective even on wet concrete and on concrete with submerged holes.



AB1

HEAVY DUTY EXPANSION ANCHOR CE1

Certified to CE option 1 for cracked and uncracked concrete and for seismic action classes C1 and C2.



AB1 A4

HEAVY DUTY EXPANSION ANCHOR CE1

Excellent mechanical performance – both static and seismic – combined with the very high corrosion resistance of stainless steel A4 | AISI316.



RELATED PRODUCTS

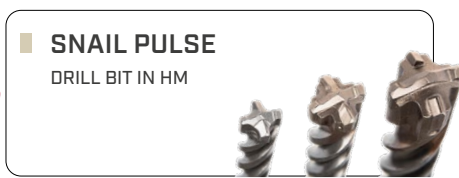

INTERNAL WALLS PROTECTION

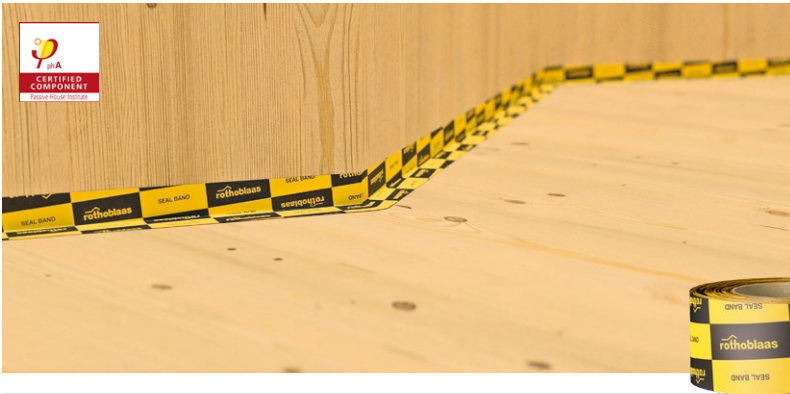

SEAL BAND

SINGLE-SIDED TAPE FOR INDOOR USE

The preformable carrier simplifies and enhances the sealing of concave or convex corners and edges. Also available in a square version, ideal for small point seals or holes using the blowing technique, where precision is required.

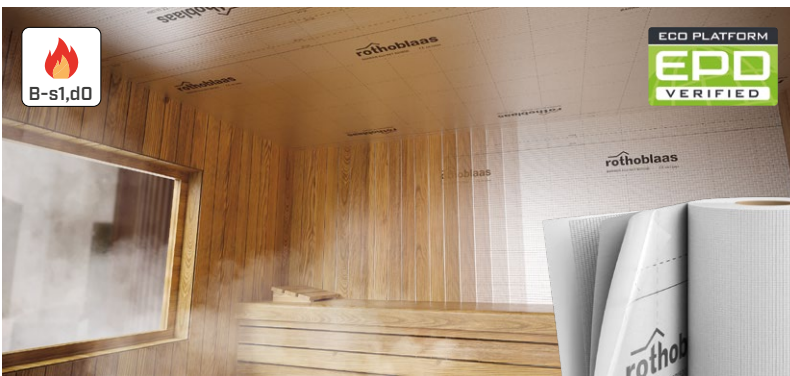

BARRIER ALU NET Sd 1500

REFLECTIVE VAPOUR BARRIER Sd > 1500 m

Thanks to its ability to reflect up to 70% of the heat, the membrane improves the thermal performance of the construction panels. Self-extinguishing membrane which does not spread the flame in case of fire contributing to the protection of the structure.



CLIMA CONTROL

MEMBRANE WITH VARIABLE VAPOUR DIFFUSION

Membranes capable of adapting their vapour diffusion resistance value (Sd) in response to changes in relative humidity. They reduce the risk of interstitial condensation within walls and roofs.

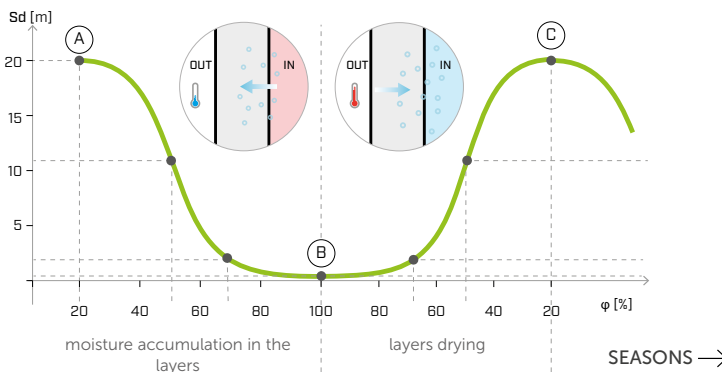

CLIMA CONTROL 80



CLIMA CONTROL 105



CLIMA CONTROL NET 160



CLIMA CONTROL NET 145

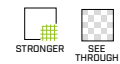

- (A) **DRY LAYERS: Sd 20 m**
maximum protection - vapour barrier to limit the passage of vapour in view of the season when moisture accumulates within the layers
- (B) **HUMID LAYERS: Sd 0,1 m**
maximum breathability - breathable membrane to allow drying during the reverse vapour diffusion phenomenon
- (C) **DRY LAYERS: Sd 20 m**
maximum protection for the start of a new year and a new cycle



We have started a project to assess the environmental impact of our products, called **EPD - Environmental Product Declaration**, a voluntary environmental declaration based on the analysis of the products' life cycle, from production to use.

WALLS DOORS/WINDOWS

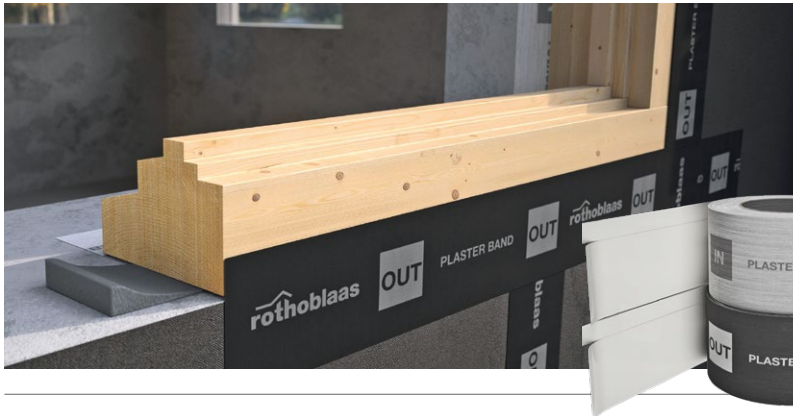

PLASTER BAND IN/OUT

SPECIAL HIGH-ADHESION TAPE, CAN BE PLASTERED

The technical fabric carrier is suitable for plastering, ensuring an excellent aesthetic finish.



WINDOW BAND

SELF-EXPANDING SEALING TAPE FOR WINDOWS/DOORS

It seals the joints of doors and windows from air and heavy rain while maintaining the thermal-acoustic properties over the entire depth.

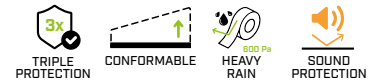

HERMETIC FOAM

HIGH PERFORMING SOUNDPROOFING SEALING FOAM

Waterproof and airtight, even if trimmed after hardening, thanks to the closed-cell structure.

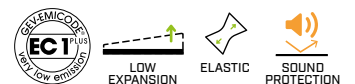

MBS - MBZ

SELF-TAPPING SCREW FOR MASONRY

The countersunk head (MBS) allows PVC window frames to be installed without damaging the frame. The cylindrical head (MBZ) is able to penetrate and remain embedded in timber frames.

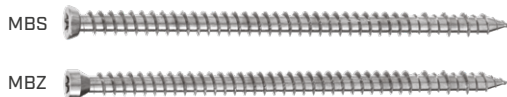

Zn
ELECTRO
PLATED

MS-SEAL

MS POLYMER HIGH ELASTICITY SEALANT

Single-component pure sealant with virtually no shrinkage and high elasticity.



RELATED PRODUCTS

FLY FOAM

AUTOMATIC LONG TUBE GUN FOR FOAMS



FOAM CLEANER

DETERGENT FOR CARTRIDGE GUNS



SEAL BAND

SINGLE-SIDED TAPE FOR INDOOR USE



PASSIVE FIRE PROTECTION

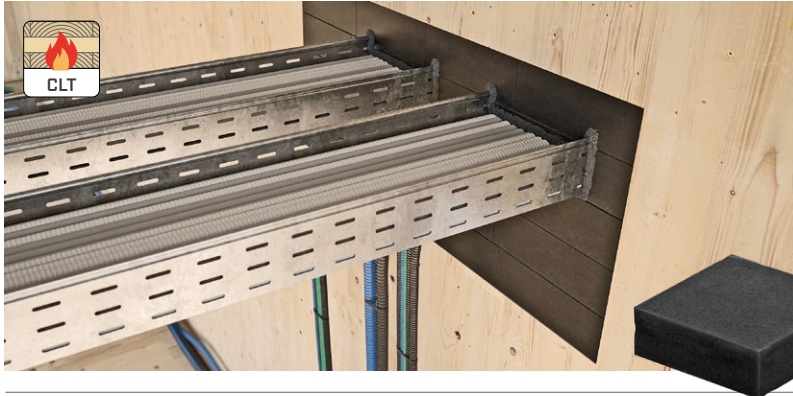

MASS

INTUMESCENT BRICK FOR MECHANICAL TECHNICAL PENETRATIONS

Made of polyurethane foam, MASS expands on contact with fire and forms an insulating barrier that counteracts the spread of flames. In case of maintenance or changes to the installation, MASS can be easily removed and repositioned.



ETA 24/1205



UNICOLLUM

ROLL OF FIRESTOP COLLAR FOR MECHANICAL AND ELECTRICAL TECHNICAL PENETRATIONS

A universal solution, it can be cut directly on-site and adapted to accommodate large diameters. It is certified for sealing mechanical and electrical penetrations in walls and ceilings.



ETA 24/1203

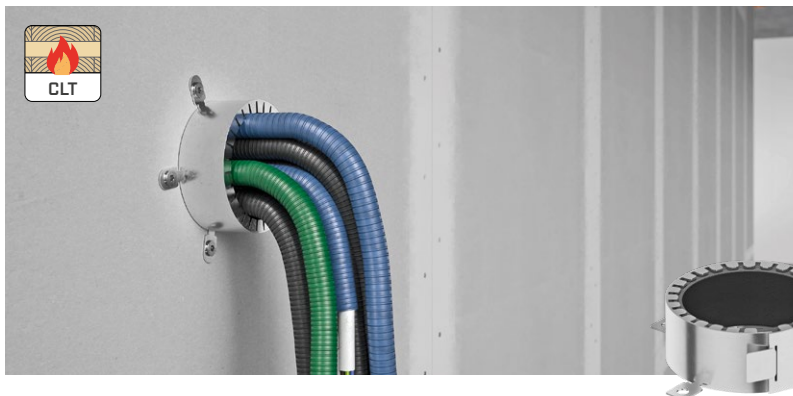

COLLUM

FIRESTOP COLLAR FOR MECHANICAL AND ELECTRICAL TECHNICAL PENETRATIONS

It can be applied to penetrations of specific types and diameters. Quick and easy installation. The outer stainless steel structure allows its application in wet environments, and the highly expansive intumescent strip ensures protection for large-sized elements.



ETA 12/1204



SACCUS

FIREPROOF BAG FOR CABLE TRAY PENETRATIONS

Easy installation with optimised dimensions for more efficient use and main types of openings. It is repositionable, facilitating maintenance and modifications to installations. It minimises the sealing depth required to contain heat transfer.



ETA 24/1082

✓ RELATED PRODUCTS

GRAPHIT FOAM

TWO-COMPONENT FIREPROOF POLYURETHANE FOAM SUPPLEMENTED WITH GRAPHITE



PANNUS

FIREPROOF COVER FOR METAL PIPE PENETRATIONS



ETA 25/0963

PANEL

PANEL WITH FIREPROOF COATING



ETA 24/1206

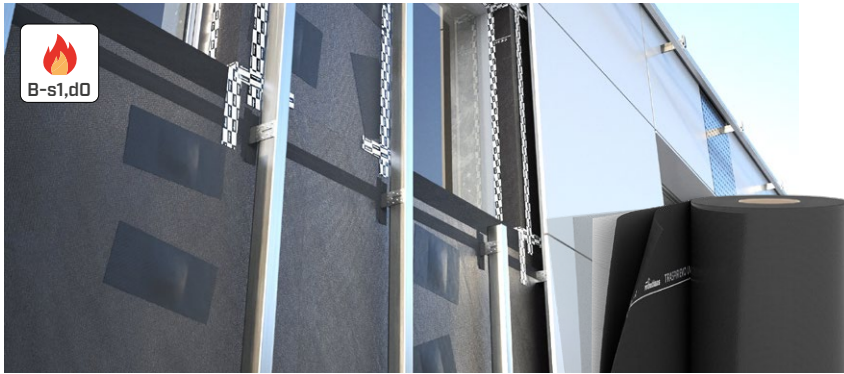

TRASPIR EVO UV ADHESIVE

SELF-ADHESIVE BREATHABLE MONOLITHIC MEMBRANE RESISTANT TO UV RAYS

Made of a special polymer blend and featuring an adhesive film, the monolithic structure ensures high resistance to atmospheric and chemical agents, guaranteeing 16 weeks of temporary protection. It has fire reaction B-s1,d0 and flame retardant capacity according to EN 13501-1.

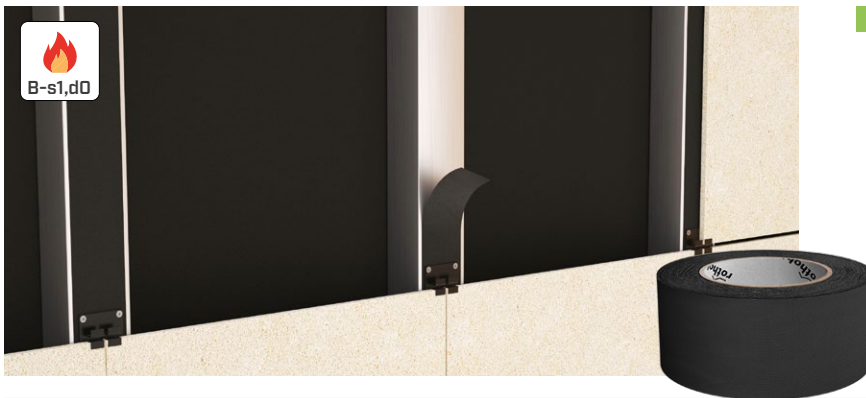

MULTI BAND UV

SPECIAL UV-RESISTANT HIGH-ADHESION TAPE

The B-s1,d0 fire reaction and flame retardant capacity according to EN 13501-1 make it one of the best performing tapes on the market.



FRONT BAND UV 210

UNIVERSAL SINGLE-SIDED TAPE, HIGHLY RESISTANT TO UV RAYS

Self-extinguishing tape that does not spread the flame in case of fire, contributing to the passive protection of the structure.

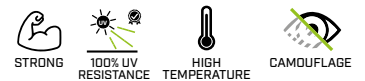

NOTES

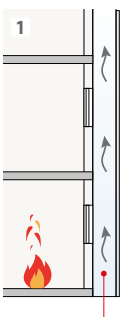

gap

In the event of a fire inside a building, flames initially spread within the compartment where they originate. Modern buildings with ventilated façades exploit the stack effect created by the cavity between cladding and insulation, which is beneficial for ventilation but hazardous in the event of fire, as it may promote fire spread.

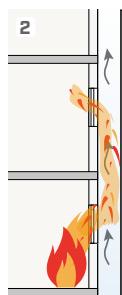

In the event of a fire, the **CHIMNEY EFFECT** of the ventilated façade could cause problems as it could direct the flames into the ventilation space, pushing them towards the upper floors of the building.

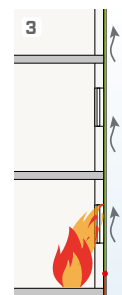

passive protection

Proper fire design provides for active or passive protection measures to prevent the spread of flames. Rothoblaas proposes self-extinguishing membranes and tapes as a passive façade protection. Without appropriate measures, flames can spread to upper floors, even in the case of an external fire.

RELATED PRODUCTS

TRASPIR EVO UV 210

HIGHLY BREATHABLE MONOLITHIC MEMBRANE RESISTANT TO UV RAYS



TRASPIR EVO 160

MONOLITHIC BREATHABLE MEMBRANE

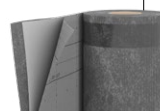

TRASPIR ALU FIRE A2 430

REFLECTIVE HIGHLY BREATHABLE MEMBRANE



TYPES OF NOISE

STRUCTURAL NOISE



Structure-borne noise occurs when sound travels through the structure, spreading vibrations not only to adjacent rooms but also to non-communicating spaces.

Solve the problem at its source – use **XYLOFON, PIANO, ALADIN STRIPE** or **GRANULO STRIPE**



ACTION

Install **XYLOFON, PIANO, ALADIN STRIPE** or **GRANULO** above and below the slab to interrupt noise transmission through the structure.



IMPACT NOISE



Walking, moving a chair, moving any object resting on the floor leads to mechanical excitation of the floor and, consequently, to what is known as impact noise.

Forget the broomstick trick – use **SILENT FLOOR BYTUM, SILENT FLOOR PE, SILENT FLOOR PUR, SILENT FLOOR 3D, SILENT EDGE, SILENT UNDERFLOOR, GRANULO**

ACTION

- ① concrete slab (t: 50 mm)
- ② **SILENT FLOOR PUR** (t: 20 mm)
- ③ CLT panel (t: 200 mm)

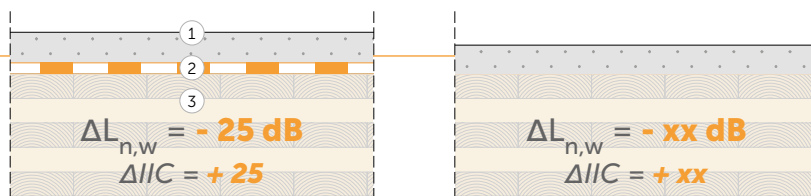

Thanks to the addition of the floating screed system on the raw CLT.

AIRBORNE NOISE



It is transmitted in the air and is part of our everyday life: chatting, listening to music, playing with children.

You can always turn the volume down, but you can also explore **SILENT WALL BYTUM, SILENT WALL BYTUM SA, GIPS BAND, SILENT GIPS** and **SILENT UNDERFLOOR**

VERTICAL PARTITIONS / LOW-THICKNESS RENOVATION

Increase mass by coupling **SILENT WALL BYTUM** or **SILENT WALL BYTUM SA** to the plasterboard panel, and insert **PIANO A, SILENT FLOOR PUR, GIPS BAND, SILENT GIPS** or **SILENT UNDERFLOOR** as a resilient layer between the base structure and the plasterboard panel.

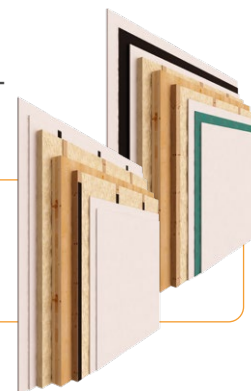

ACOUSTIC AND SEALING



The sound wave propagates in the air, which makes it easy to spread and difficult to control. Precise design of airtightness and service systems ensures careful consideration of all aspects, without overlooking the details that could compromise the building's acoustic performance. Discover the most suitable solutions in the **TAPES, MEMBRANES, SEALANTS AND FIRE PROTECTION** catalogue available on our website.

Discover the complete **SOUNDPROOFING SOLUTIONS** range on our website or request the catalogue from your salesman.
www.rothoblaas.com



FLOOR SOUNDPROOFING

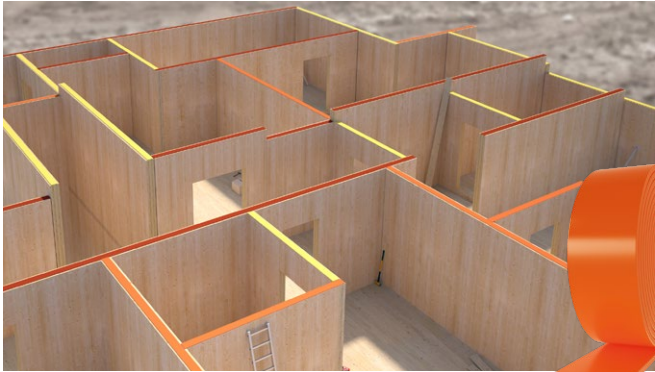

XYLOFON

HIGH PERFORMANCE RESILIENT SOUNDPROOFING PROFILE

A resilient profile ensuring high acoustic comfort, suitable for any construction system – not only timber, but also steel and concrete. Made from a durable and stable polyurethane compound, it is available in six versions from 20 to 90 Shore, depending on the load it is required to support.

The product is tested and certified for use as a desolidarisation and mechanical interruption layer between building materials, it significantly reduces the transmission of airborne and structural noise (from 5 to more than 15 dB). The low thickness of the six versions can support a wide range of loads without affecting the design choices.



PIANO

RESILIENT SOUNDPROOFING PROFILE

It reduces vibrations and provides good acoustic comfort, both in lightweight floors and in more complex, high-load buildings. Made of expanded and extruded EPDM blend, it is available in five versions. The elastic compound compensates for timber and structural movement, while the compact cross-section provides greater resistance to compression.

Piano is tested and certified for use as a desolidarisation and mechanical interruption layer between building materials. The acoustic performance tested in various applications ensures a noise reduction of 4-5 dB with a good cost-performance balance.



SILENT FLOOR

SOLUTIONS AGAINST IMPACT NOISE

With regard to the flooring, there is a need for underfloor insulation solutions. These are elements with the task of absorbing vibrations and this is made possible by their ability to absorb the energy released during impact on the floor. If this energy is left without barriers, it would otherwise be converted into sound waves, disturbing adjacent rooms.

Our range of underscreeds offers different solutions depending on the weight of the top layers installed on the resilient products (screed thickness).

Test results of all products in this family are also available in real applications with effectiveness between 30 and 40 dB. The range consists of different solutions in made of different materials depending on the intended use.

RELATED PRODUCTS

XYLOFON PLATE

SEPARATING PROFILE FOR
TIMBER SHEAR BRACKET
ANGLES

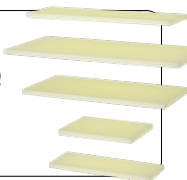

ALADIN

RESILIENT SOUNDPROOFING
PROFILE



HAMMER STAPLER 22

LARGE HAMMER
STAPLER



FLOOR FASTENING

HBS

COUNTERSUNK SCREW FOR WOOD

HBS: Certified for structural applications, it has a high wood pull-through capacity and superior seismic performance.

HBS EVO: Thanks to its special surface treatment, it can be used in service class 3 and atmospheric corrosivity class C4.

HBS HARDWOOD: The special tip with diamond geometry and notched, serrated thread, makes the screw certified for use with high-density woods with no need for pre-drilling.

HBS



HBS EVO



HBS HARDWOOD

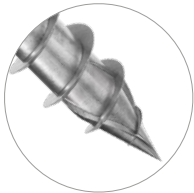

3 THORNS

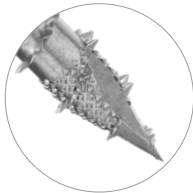

HARD WOOD
TIMBER



TBS

FLANGE HEAD SCREW

TBS: it is distinguished from the common wood screw thanks to the flange head, which performs the function of a washer and ensures high tensile strength. The TBS screw is approved for structural applications subject to stresses in any direction vs. the grain ($\alpha = 0^\circ - 90^\circ$).

TBS EVO: Thanks to its special surface treatment, it can be used in service class 3 and atmospheric corrosivity class C4.

TBS MAX: greater thread length (60%) to ensure superb joint closure and great versatility. Optimised geometry for maximum performance on the most common construction timbers.

TBS



TBS EVO



TBS MAX



TBS MAX



CTC

CONNECTOR FOR TIMBER-CONCRETE FLOORS

Specifically designed for timber-concrete slabs. It is an approved self-drilling, reversible, fast and minimally invasive system.



Discover the complete range **OF SCREWS FOR TIMBER** on our website or request the catalogue from your salesman.
www.rothoblaas.com



FLOOR FASTENING



TITAN PLATE 1200

PLATE FOR SHEAR LOADS

The 1.2 m long version allows the creation of long connections in panel floors, replacing the classic spline joint connection. CE marking according to European standard EN 14545



SLOT

CONNECTOR FOR STRUCTURAL PANELS

It allows very high stiff joints and can transfer exceptional shear stresses between the panels. Ideal for walls and floors. The honeycomb geometry and lightweight aluminium ensure excellent performance: one connector can replace up to 60 Ø6 screws.



SHARP METAL

STEEL HOOKED PLATES

The plates have a multitude of small hooks spread over the two surfaces. The joint is made by mechanically inserting the hooks into the timber. The hooks pull-through into the timber can be achieved by the compression generated by the TBS MAX flange head screws.



✓ RELATED PRODUCTS

TBS MAX
XL FLANGE
HEAD SCREW

LBS
ROUND HEAD SCREW
FOR PLATES

SHIM SLOT
STEEL SPACERS
FOR SLOT
CONNECTOR

AIR AND WIND TIGHTNESS FIELDS OF APPLICATION

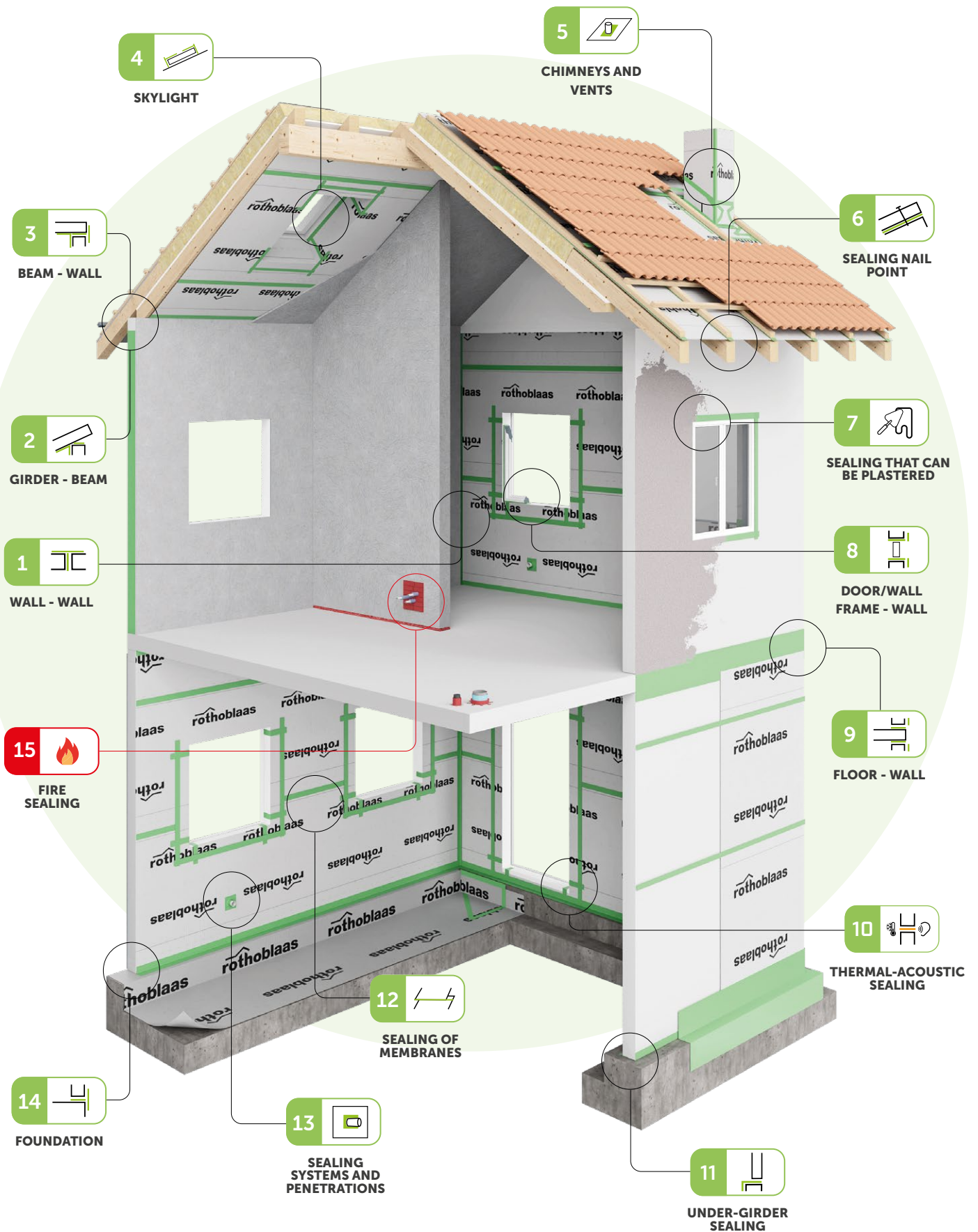

AIR AND WIND TIGHTNESS TAPES

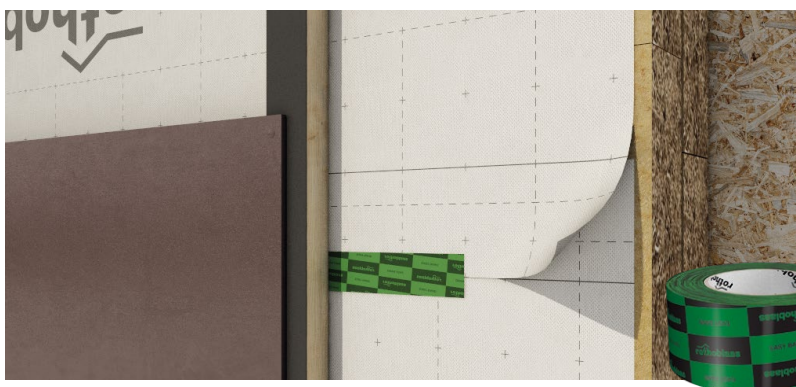

EASY BAND

UNIVERSAL SINGLE-SIDED TAPE

Progress adhesion, stable over time, for the most common supports. Adhesive mix and versions designed for prefabrication are also available.

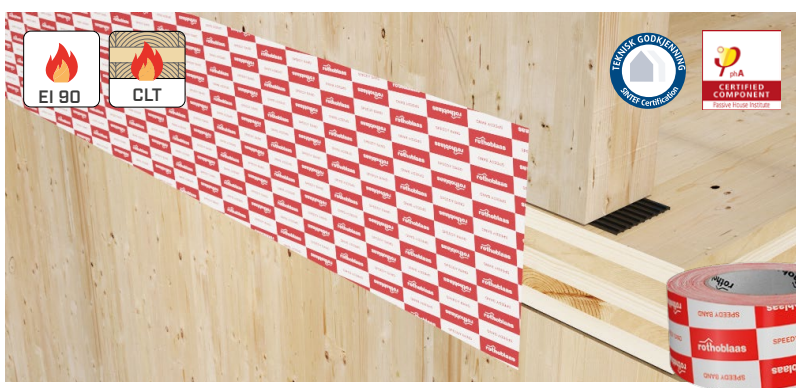

SPEEDY BAND

UNIVERSAL SINGLE-SIDED TAPE WITHOUT RELEASE LAYER

Can be applied both internally and externally, guarantees fast and secure sealing on the most common materials. The lack of a release liner means less waste to dispose of.

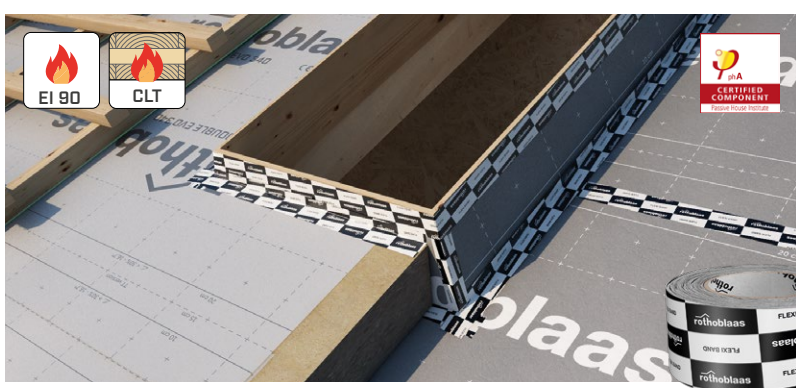

FLEXI BAND

UNIVERSAL SINGLE-SIDED HIGH-ADHESIVE TAPE

Ensures excellent adhesion strength and resistance on all surfaces. The special adhesive compound guarantees long-term functionality even under sub-optimal conditions, e.g. on dusty or damp surfaces.

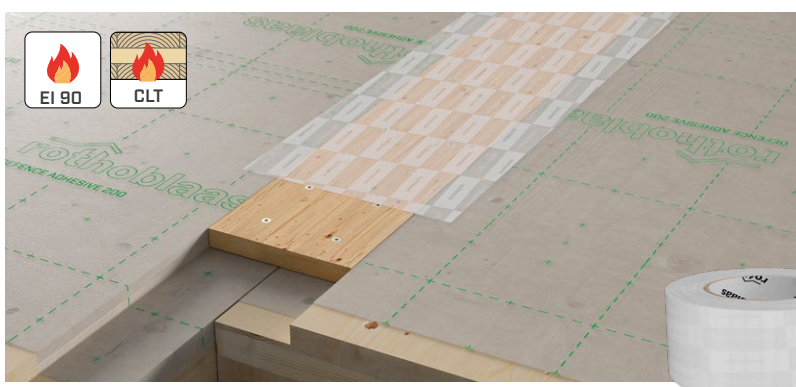

INVISI BAND

TRANSPARENT SINGLE-SIDED ADHESIVE TAPE WITHOUT LINER, RESISTANT TO UV AND HIGH TEMPERATURES

Transparent: it allows for the inspection of any type of sealing performed, especially in the case of joints between timber panels. Adhesion and mechanical properties remain unchanged over time. It is airtight and waterproof.



RELATED PRODUCTS

PRIMER

UNIVERSAL PRIMER FOR ACRYLIC ADHESIVE TAPES



PRIMER SPRAY

UNIVERSAL SPRAY PRIMER FOR ACRYLIC ADHESIVE TAPES



ROLLER

ROLLER FOR TAPES



WATERPROOFING

BREATHABLE AND VAPOUR CONTROL MEMBRANE

BREATHABLE AND VAPOUR CONTROL MEMBRANE CLASSIFICATION

Membranes can be grouped into 3 categories, based on their characteristics:

	AIRTIGHTNESS	WATERTIGHTNESS	RESISTANCE TO WATER VAPOUR
Vapour barriers	●●●	●●●	●●●
Vapour control membranes	●●●	●●●	●●○
Breathable membranes	●●●	●●●	○○○

The properties described here, together with other parameters mentioned in the technical data sheets, are regulated by the CE marking protocol for vapour control membranes (EN 13984), underlays for discontinuous roofing (EN 13859-1) and wall underlays (EN 13859-2).

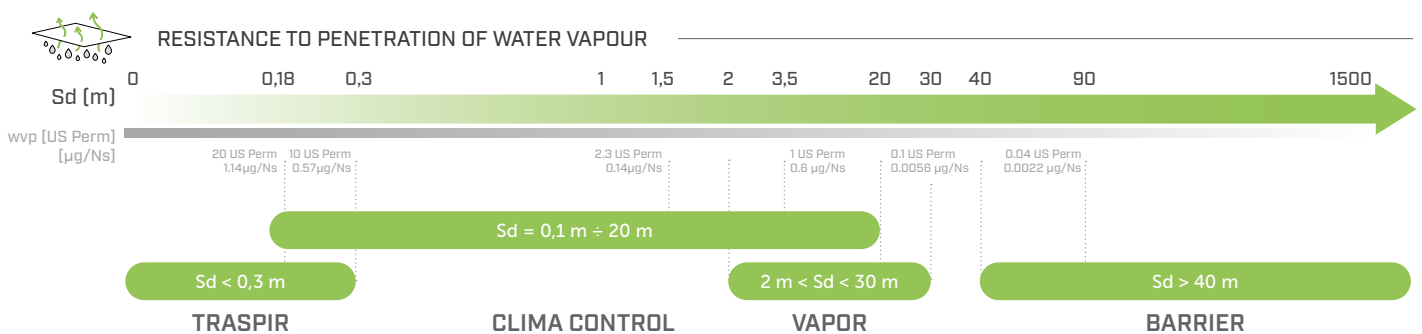

BARRIER AND VAPOR

VAPOUR BARRIERS AND VAPOUR CONTROL LAYERS

High vapour diffusion resistance membranes designed to control moisture flow towards the colder layers of the building envelope. They act as an airtight layer and protect insulation materials.

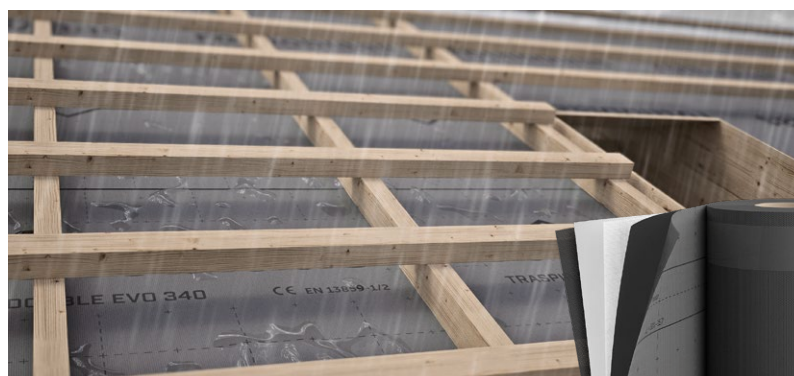

TRASPIR

BREATHABLE MEMBRANES

Breathable membranes that allow vapour to pass outwards while ensuring impermeability in the most exposed layers. They protect insulation in the event of accidental damage to roofs and façade cladding and act as a temporary protective layer during construction.

Download the **TAPES, MEMBRANES, SEALANTS AND FIRE PROTECTION** catalogue - the only element that protects you from the others.
www.rothoblaas.com



PROTECTION WITH SELF-ADHESIVE MEMBRANE

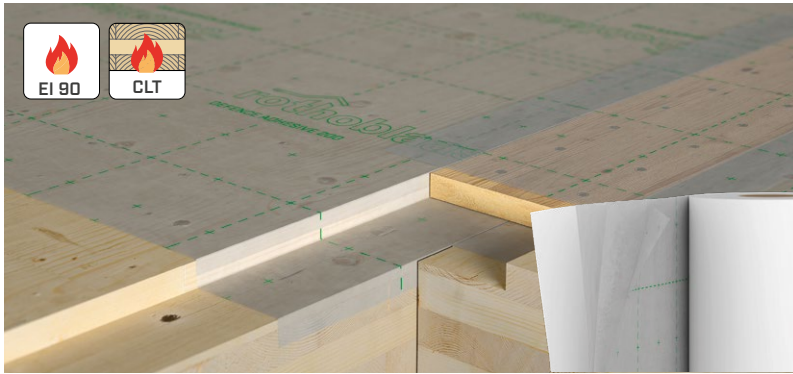

DEFENCE ADHESIVE

SELF-ADHESIVE PROTECTIVE MEMBRANE FOR BUILDING ELEMENTS

The product, once applied, is invisible and allows both the markings of the powder tracer on the panel and the mounting holes to be easily seen. The membrane protects the timber without interfering with either handling or site operations. Waterproof and non-slip.



DEFENCE ADHESIVE REMOVABLE

SELF-ADHESIVE PROTECTIVE MEMBRANE REMOVABLE

Protects building elements from dust, dirt and impurities, preserving the original appearance of materials. Prevents colour variation and timber yellowing during construction. It allows for quick and easy removal of the membrane at the end of construction.



DEFENCE ADHESIVE SPEEDY

SELF-ADHESIVE PROTECTIVE MEMBRANE WITHOUT RELEASE LINER

Quick and easy installation. The protection of building elements is guaranteed for 12 weeks, and if an error is made during installation, the membrane can be easily repositioned and reapplied within the first few minutes. The lack of a release liner means less waste to dispose of.

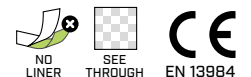

DEFENCE ADHESIVE TRASPIR EVO

SELF-ADHESIVE BREATHABLE MEMBRANE MONOLITHIC

The homogeneous and continuous monolithic functional layer provides maximum protection against the passage of water and high breathability. The special compound ensures significant weather resistance and excellent durability over time.



FROM THEORY TO INSTALLATION

On the Rothoblaas BLOG you'll find technical articles on waterproofing to guide you in your on-site choices.



CONSTRUCTION SITE LIFTING AND POSITIONING

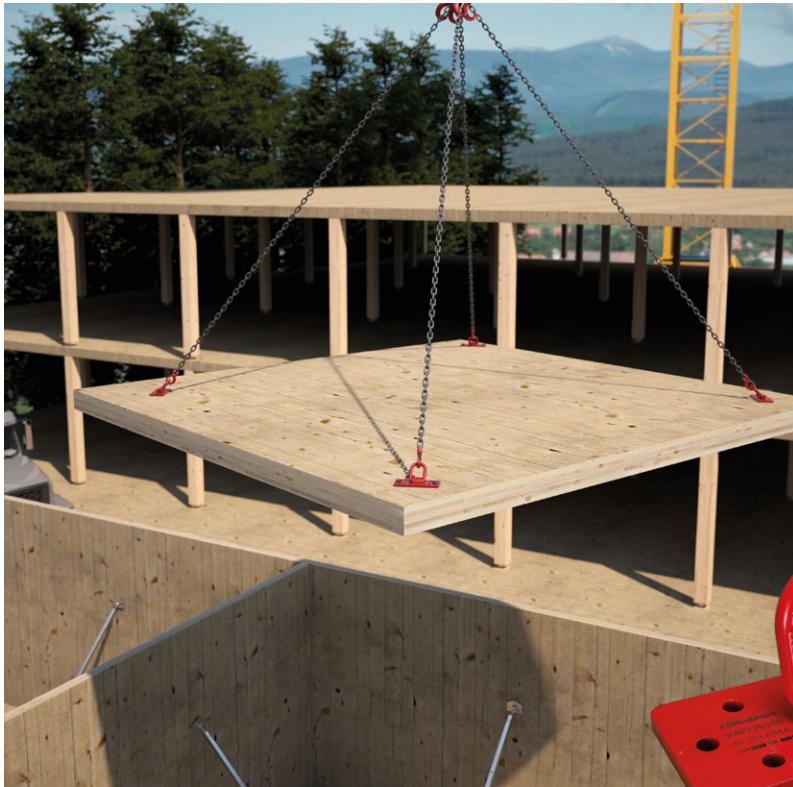

RAPTOR

RIGGING DEVICE FOR TIMBER ELEMENTS

It can be installed with configurations that make it suitable for the most common applications on the construction site:

- 6 screws: maximum strength and capacity
- 4 or 2 screws: for lifting and transporting lighter panels

It can be used to work with any inclination of the chain, working effectively in both tension and shear, but also in intermediate configurations.



GIRAFFE

ASSEMBLY SUPPORT

For quick and easy assembly of walls and floors made of timber elements. Quick adjustment with automatic lock. Also available in the 6 metre version.

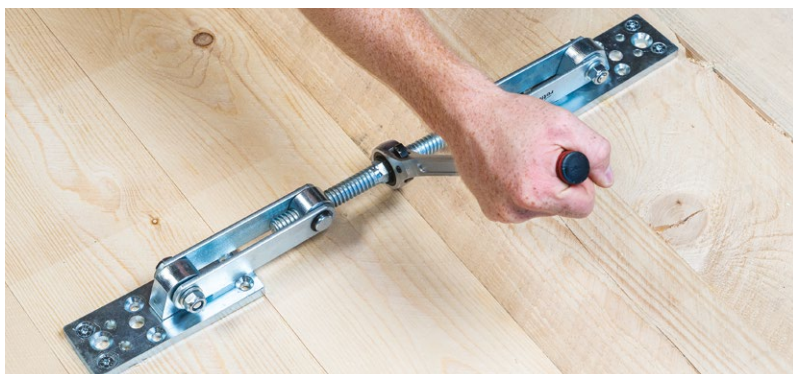

GEKO

PANEL PULLER

For the precise assembly of solid timber panels, stacked board floors, glulam elements and more. 360° rotating plates enable use even in hard-to-reach areas, such as corners and roof slopes

✓ RELATED PRODUCTS

RAPTOR MINI

SMALL RIGGING DEVICE FOR
TIMBER ELEMENTS



RAPTOR MAXI

LARGE RIGGING DEVICE FOR
TIMBER ELEMENTS



VGS PLATE

PAN HEAD HEX SCREW FOR
LIFTING



POST AND BEAM CONCEALED JOINTS



LOCK FLOOR

JOINT PROFILE FOR PANELS

Ideal for connecting floor panels to multi-story walls (concrete or timber). The hooking system enables installation without the use of shoring or temporary support structures. The profiles can be pre-installed on panels and walls, without additional fastening on site during installation.

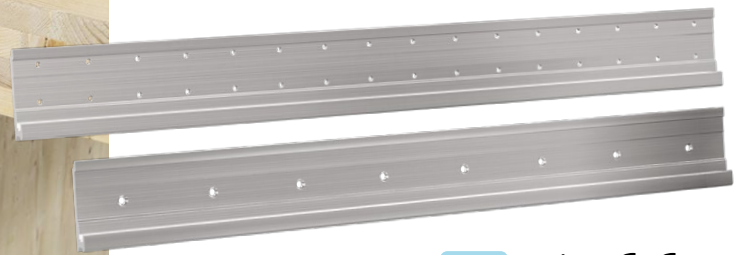

LOCK T

CONCEALED TIMBER-TO-TIMBER CONNECTOR

Ideal for carports, pergolas, canopies or post-and-beam structures. It can also be used concealed with wooden elements having small cross-section.



ALU

CONCEALED BRACKET WITH AND WITHOUT HOLES

Concealed aluminium joints designed for structural timber-to-timber and timber-to-steel connections. The range of available sizes allows for increasing load-bearing capacities and the integration of connections within construction systems, without visible elements.



✓ RELATED PRODUCTS

LOCK C

CONCEALED
TIMBER-TO-CONCRETE
CONNECTOR



STA

SMOOTH DOWEL



FIRE STRIPE GRAFITE

FLEXIBLE INTUMESCENT
GASKET

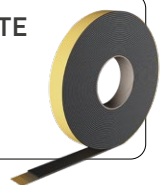

POST AND BEAM

HINGED BEAM JOINTS



ALUMEGA

PINNED CONNECTION FOR POST AND BEAM

It standardizes the beam-to-beam and beam-to-column connections for post-and-beam systems, even with large spans. Modular components and various fastening possibilities solve all types of connections on timber, concrete or steel.

Axial tolerance up to 8 mm (± 4 mm) to accommodate installation inaccuracies. The upper notch allows using a bolt as a positioning aid. The connection can be pre-assembled in the factory and completed on site with bolts.

Slotted holes allow rotation of the connector and ensure hinged structural behaviour. The rotation of the connector is compatible with the inter-storey drift caused by earthquake and wind actions, reducing momentum transfer and structural damage.

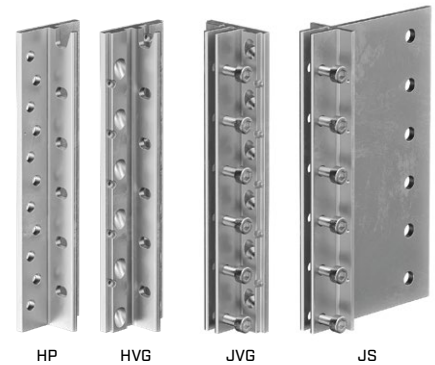

INTER-STOREY DRIFT FOR HORIZONTAL ACTIONS

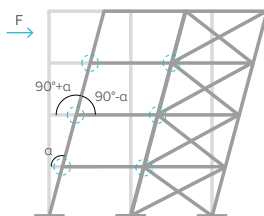

The connector's rotation capacity is compatible, depending on the installation setup, with inter-storey drift caused by seismic or wind actions.

ROTATION FOR GRAVITATIONAL LOADS

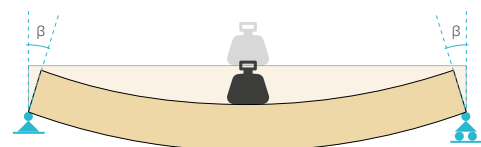

For gravitational loads, the connector has a hinged structural behaviour and ensures free rotation at the ends of the beam, provided that the connection detail actually enables such rotation.

RELATED PRODUCTS

HBS PLATE

PAN HEAD SCREW FOR PLATES



JIG ALUMEGA

DRILLING TEMPLATE FOR ALUMEGA HVG-JVG



VGS

FULLY THREADED SCREW WITH COUNTERSUNK OR HEXAGONAL HEAD



POST AND BEAM BEAM REINFORCEMENT

VGZ

FULLY THREADED SCREW WITH CYLINDRICAL HEAD

VGZ: the wood screws with total thread are ideal for concealed joints, timber couplings and structural reinforcements. Available in an extremely large range of sizes, they guarantee fire protection and earthquake suitability.

VGZ EVO: ideal for fastening timber elements in aggressive external environments (C4) and in service class 3, thanks to its multi-layer epoxy matrix coating with aluminium flakes.

VGZ HARDWOOD: the hardwood screw featuring a special tip with diamond geometry and notched, serrated thread. It is certified for use with high-density hard woods without pre-drilling, and it is ideal for concealed joints, timber couplings and structural reinforcements.

VGZ



VGZ EVO



VGZ HARDWOOD

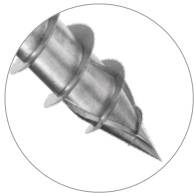

3 THORNS

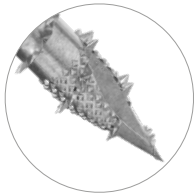

HARD WOOD
TIMBER



VGS

FULLY THREADED SCREW WITH COUNTERSUNK OR HEXAGONAL HEAD

VGS: with deep thread and high strength steel for excellent tensile or sliding performance. Approved for structural applications subject to stresses in any direction vs the grain ($0^\circ \div 90^\circ$). Can be used on steel plates in combination with the VGU and HUS washers.

VGS EVO: featuring a 20 µm multi-layer C4 EVO epoxy matrix coating with aluminium flakes, compliant with corrosion resistance requirements according to ISO 9227.

VGS A4: made of A4 | AISI316 stainless steel for high corrosion resistance. Ideal for environments adjacent to the sea in corrosivity class C5 and for insertion on the most aggressive timbers in class T5.

VGS



VGS EVO



VGS A4

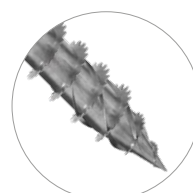
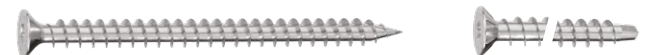

SHARP SAW NIBS

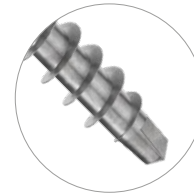

SELF-DRILLING



VGS PLATE

PAN HEAD HEX SCREW FOR LIFTING

Compatible with all transport and lifting systems using screws. Designed for repeated use during transport.



RELATED PRODUCTS

JIG VGZ 45°

TEMPLATE FOR 45°
SCREW CONNECTIONS



VGU

45° WASHER
FOR VGS



JIG REUSE

INSPECTION TEM-
PLATE FOR REUSA-
BLE SCREWS



WASP

HOOK FOR TIMBER
ELEMENTS
TRANSPORT



POST AND SLAB COLUMN-TO-SLAB CONNECTIONS

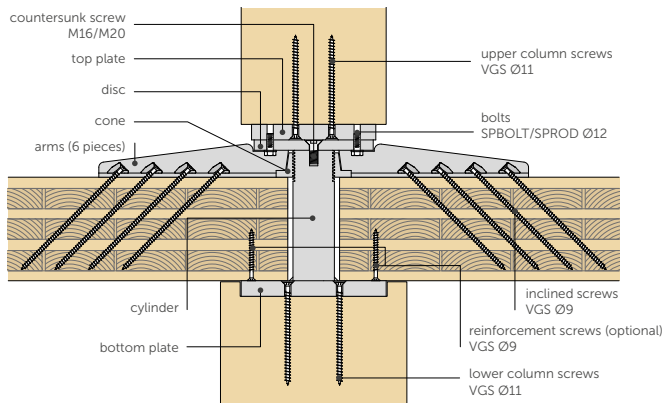

SPIDER CONNECTION AND REINFORCEMENT SYSTEM FOR COLUMNS AND FLOORS

It allows the construction of multi-storey buildings with column-to-floor structure that until now were impossible to build, with a distance between the columns of more than 7.0 x 7.0 meters of structural mesh, and allows to transfer more than 5000 kN of vertical force between the pillars.

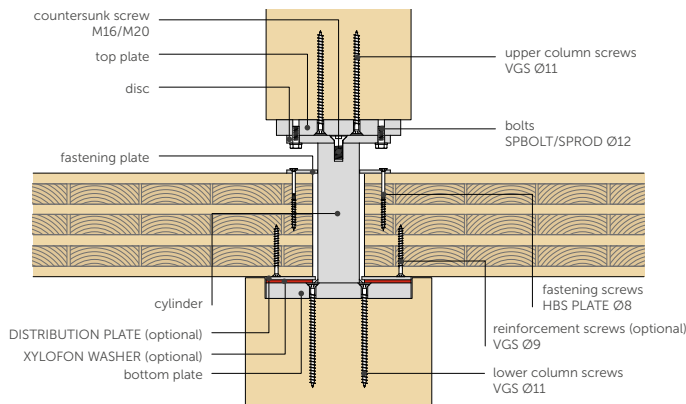

PILLAR COLUMN-TO-FLOOR CONNECTION SYSTEM

PILLAR is the revolutionary connection system that allows to build structures with column-to-floor system that until now were impossible to build, with a distance between the columns up to 3.5 x 7.0 meters.

It allows the transfer of more than 5000 kN of vertical force between the pillars.



RELATED PRODUCTS

VGS

FULL THREAD
CONNECTOR WITH
COUNTERSUNK HEAD



HBS PLATE

PAN HEAD SCREW FOR
PLATES



XYLOFON WASHER

SEPARATING WASHER
FOR SCREWS



POST AND SLAB

SLAB-TO-SLAB CONNECTIONS

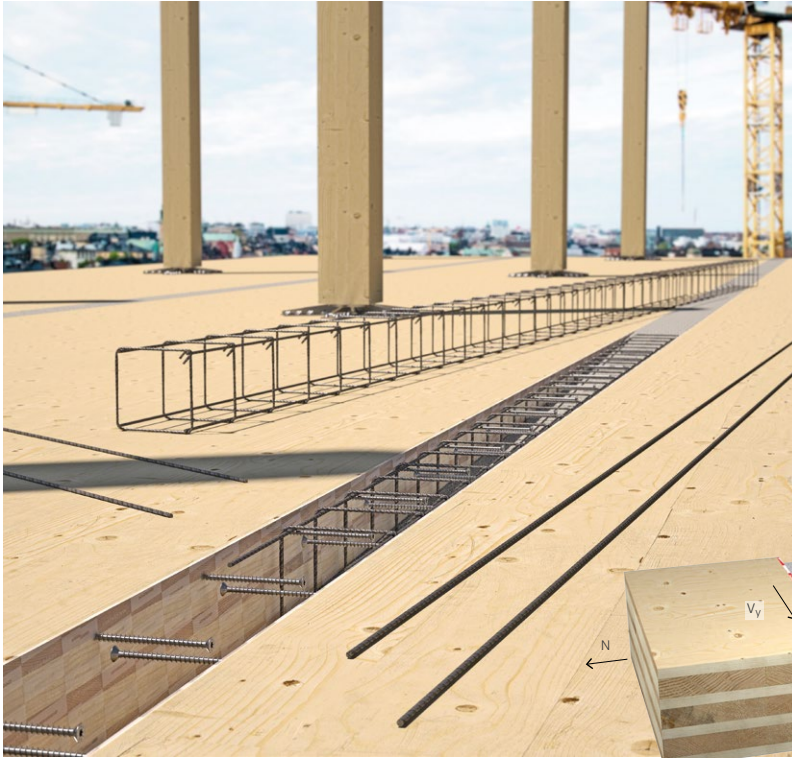

TC FUSION

TIMBER-TO-CONCRETE JOINT SYSTEM

The concrete prefabrication combines with timber prefabrication: the reinforcing bars inserted into the concrete casting accommodate the full thread timber connectors; the supplementary casting carried out after installing the timber components completes the connection.

It allows connections between CLT panels with exceptional strength and stiffness for shear, bending moment and axial stress. It is the natural complement to the SPIDER and PILLAR systems.

ETA 22/0806 is specifically for timber-concrete applications with VGS, VGZ and RTR all-thread connectors.

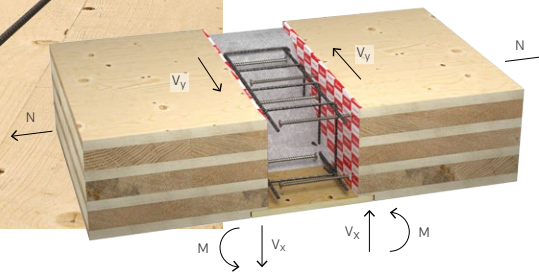

✓ RELATED PRODUCTS

VGS

FULL THREAD
CONNECTOR WITH
COUNTERSUNK HEAD



VGZ

FULLY THREADED
SCREW WITH
CYLINDRICAL HEAD



RTR

STRUCTURAL
REINFORCEMENT
SYSTEM

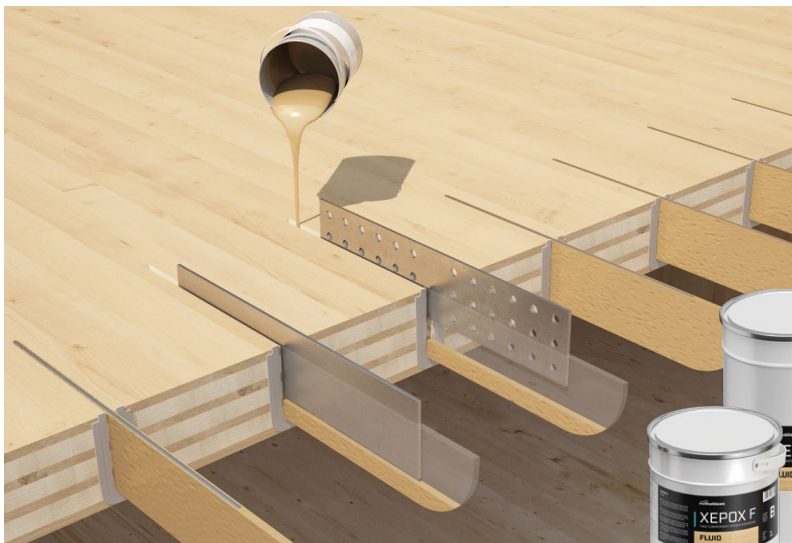

XEPOX®

TWO COMPONENTS EPOXY ADHESIVE

Moment connection made with steel plates glued in vertical grooving into the panel. The connection geometry ensures moment resistance.

The use of a high-performance material such as steel in combination with epoxy resin guarantees excellent performance in terms of strength and flexural stiffness.



✓ RELATED PRODUCTS

XEPOX F

FLUID
Suitable for injection into
holes and routings



XEPOX L

LIQUID
Suitable for casting



MAMMOTH DOUBLE

SPECIAL GUN FOR TWO-
COMPONENT ADHESIVE



HYBRID CONSTRUCTIONS TIMBER-TO-STEEL



RADIAL

CONNECTORS FOR TIMBER BEAMS AND PANELS

Ideal for making connections for either walls, beams and columns. By using RADIALKIT components, it is possible to have a tensile connection with exceptional installation tolerance. The connection remains concealed in the wall thickness.



RING

REMOVABLE CONNECTOR FOR STRUCTURAL PANELS

The high strength of the connector makes it possible to reduce the number of fastenings. Simple processing of the panel is required, resulting in easy transport and installation, speeded up by operations performed only on one side of the wall.



DISC FLAT

REMOVABLE CONCEALED CONNECTOR

Excellent initial tack and superior adhesion strength even on dusty, porous or damp surfaces. In the internal test campaign on the adhesion strength of the best-performing tapes in the range, it recorded the highest values in the peeling tests on OSB supports at 90° and 180° in the acrylic tape category.



HBS PLATE

PAN HEAD SCREW FOR PLATES

The under-head shoulder achieves an interlocking effect with the circular hole in the plate, thus guaranteeing excellent static performance. The edgeless geometry of the head reduces stress concentration points and gives the screw strength.



RELATED PRODUCTS

TORQUE LIMITER
TORQUE LIMITER

HBS PLATE EVO
PAN HEAD SCREW FOR PLATES

HBS PLATE A4
PAN HEAD SCREW FOR PLATES

HUS 15°
15° ANGLED WASHER

TOOLS STORAGE



CONTAINER

PORTABLE STORAGE FOR THE WORKSITE

Protects tools and construction materials, and safeguards machines, keeping them secure and dry. Available in two sizes; it can also be fitted with an electrical system and shelving. The shelving (optional) allows tools and products to be stored neatly, in an easily accessible manner.



SHELVA

SHELVING FOR SCREWS AND MATERIALS

Wide and stable shelves, ideal for organising and storing boxes of screws and other materials. Three possible positions: one horizontal and two angled, to be selected based on need. The side edges prevent items from falling off. No limits to configuration.



RELATED PRODUCTS

RBBOX
CONTAINER
30 x 80 cm



CAP
TARPAULINS
FOR ROOFS

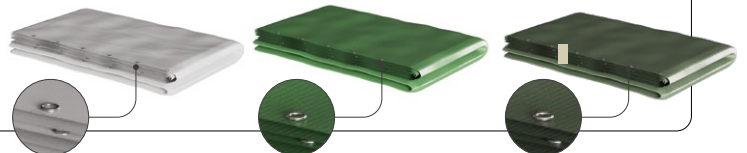

OUTDOOR POST BASES

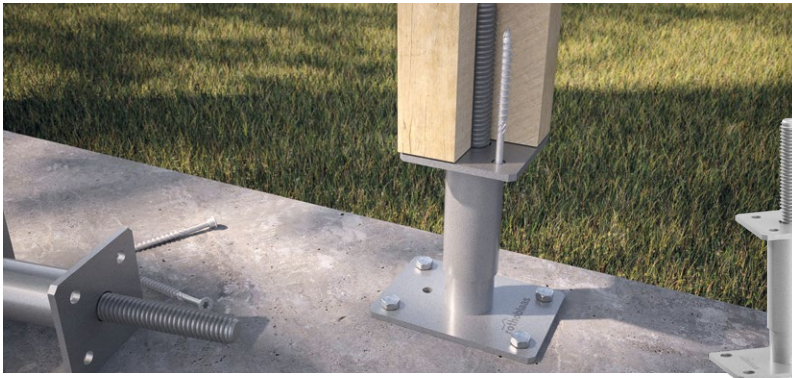

R10-R20

ADJUSTABLE POST BASE

Adjustable height, also after the product has been assembled. The regulation system is concealed by the sleeve, for optimal aesthetics. Outdistanced from the ground to prevent water splash and stagnation and ensure high durability.



S50

HIGHLY-RESISTANT POST BASE

Characteristic compression strength of more than 300 kN. Ideal for large columns. It ensures spacing from the ground to avoid water splashing or stagnation and provides high durability. Hot-dip galvanisation ensures durability in outdoor contexts.



F70

"T" SHAPED POST BASE

The internal knife plate is used to create a totally concealed joint. Designed to accommodate columns of all dimensions. Hot-dip galvanisation and aluminium versions ensure durability in outdoor settings. Without holes, to be used with SBD self-drilling dowels; with holes, to be used with smooth dowels or bolts.



SBD

SELF-DRILLING DOWEL

The new tapered self-perforating tip minimises insertion times in timber-to-metal connection systems and guarantees applications in hard-to-reach positions.



✓ RELATED PRODUCTS

X10
CROSS-SHAPED
POST BASE

EPO-FIX
HIGH-PERFORMANCE
EPOXY CHEMICAL
ANCHOR

LEWIS
TWIST DRILL BITS
FOR DEEP DRILLING

TAPS
TIMBER CAPS

OUTDOOR DECKS AND FAÇADES



ALU TERRACE

ALUMINIUM PROFILE FOR DECKS

ALUTERRA30 version for standard loads. ALUTERRA50 version, in black, for very high loads; can be used on both sides.

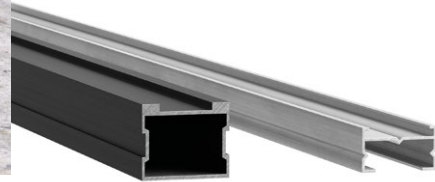

alu



SUPPORT

ADJUSTABLE SUPPORT FOR DECKS

Adjustable in height, it enables levelling of the substructure in the creation of terraces in outdoor environments. Available in three versions, for raised sections of different heights.



SCI A2 | AISI304

COUNTERSUNK SCREW

High corrosion resistance. Suitable for outdoor applications up to 1 km from the sea in class C4 on most acid woods in class T4.



KKF AISI410

PAN HEAD SCREW

Stainless steel timber screw designed for fastening timber or WPC decking boards in aggressive environments.



EWS

CONVEX HEAD SCREW

Countersunk teardrop shaped head with curved surface for a pleasant look and firm grip with the bit.



KKT COLOR

CONE-SHAPED CONCEALED HEAD SCREW

Durability is guaranteed by the anti-corrosion coating. Available in A4 version | AISI316 for highly aggressive environments.



✓ RELATED PRODUCTS

FLAT | FLIP
CONNECTOR FOR
DECKS



TERRALOCK
CONNECTOR FOR
DECKS



KKA COLOR
SELF-DRILLING SCREW
FOR ALUMINIUM





TOWER XL

SUPPORT FOR LIFELINE SYSTEMS OR ANCHOR POINTS WITH ENLARGED BASE PLATE

Modular support for lifeline systems and anchor points on timber, sheet metal, concrete and aerated concrete roofs. TOWER XL is a controlled-deformation device designed to reduce bending moments. When combined with the AOS01 eye bolt, it creates an anchor point capable of withstanding in-plane loads in all directions.



HORIZONTAL NET

HORIZONTAL POLYPROPYLENE FALL PROTECTION SAFETY NET

It is a fall protection safety net that requires a limited number of fastening systems: it is sufficient to respect the maximum distance between anchor systems of 2.5 m.



PATROL + T-CLAMP

LIFELINE ON SUPPORT FOR CONTINUOUS ROOFS

A versatile system with special clamps allowing installation on various types of metal roofs.

BORDER: ALUMINIUM PERMANENT AND TEMPORARY RAILINGS

SELF-SUPPORTING RAILING

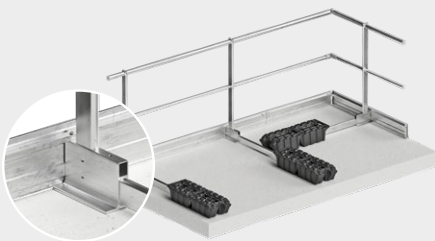

RAILING VERTICAL AND VERTICAL SPACED FASTENING

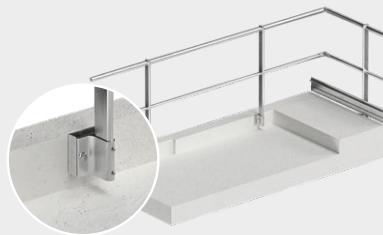

HORIZONTAL FASTENING RAILING

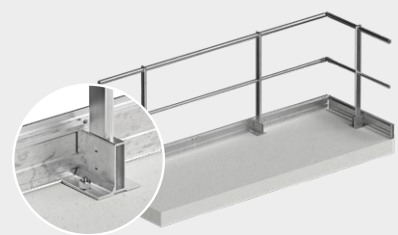

RAILING FASTENING ON TRAPEZOIDAL METAL ROOF



A Z FASTENING RAILING

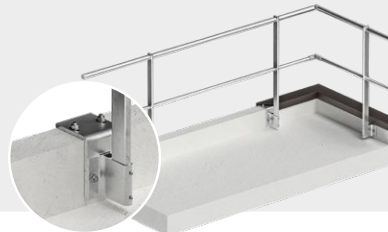

FALL PROTECTION

PERSONAL PROTECTIVE EQUIPMENT

HERO

HELMET FOR WORK AT HEIGHT, ON CONSTRUCTION SITES OR IN INDUSTRIAL AREAS

Lightweight, with a sporty design, featuring wheel ratchet size adjustment. Ventilation ensures comfort even on the hottest days.



YOUR HELMET

Buy HERO and make it yours! Customise the helmet by adding a sticker with your logo. Ask your trusted agent for more information!



ROOF MID KIT

INTERMEDIATE KIT FOR WORKING ON ROOF

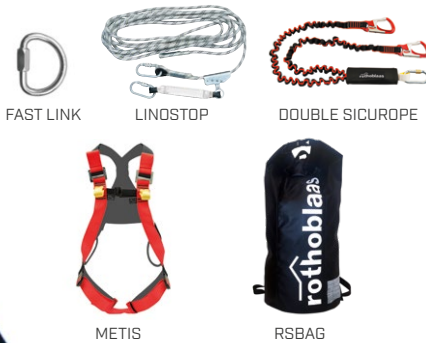

SCAFFOLD BASE KIT

BASE KIT FOR WORKING ON SCAFFOLDING



WHEN YOU WORK AT HEIGHT WORK SAFELY

The **FALL PROTECTION SYSTEMS AND PROTECTIVE EQUIPMENT** catalogue is the comprehensive guide for working at height in complete safety, in the construction and industrial sectors. Advanced technologies, maximum protection and regulatory compliance – all in the one resource.

Download it now!

rothoblaas.com

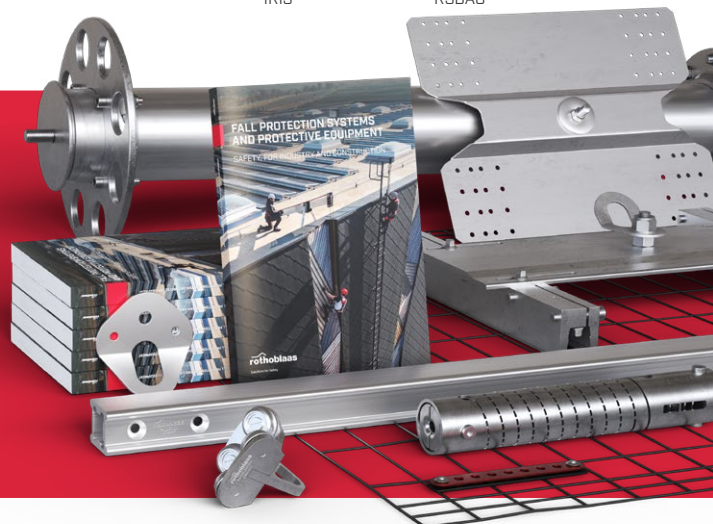

- FASTENING
- AIRTIGHTNESS AND WATERPROOFING
- SOUNDPROOFING
- FALL PROTECTION
- TOOLS AND MACHINES

rothoschool



Thanks to partnerships with universities, research centres and specialised companies worldwide, Rothoblaas courses bring speakers into the classroom with practical experience and proven expertise in technical consultancy. The training offer combines theoretical knowledge with practical application and is aimed at engineers, architects, carpenters, safety specialists and other professionals in the construction sector.

ROTHOSCHOOL ON TOUR

We bring training directly to local areas, with hands-on sessions for industry professionals.

FIND THE COURSE THAT SUITS YOU!

www.rothoblaas.com/rothoschool

